

# Toward a revival of Stellar Intensity Interferometry

Stephan LeBohec<sup>1</sup>, Cesare Barbieri<sup>2</sup>, Willem-Jan de Wit<sup>3</sup>, Dainis Dravins<sup>4</sup>, Philippe Feautrier<sup>5</sup>,  
Cédric Foellmi<sup>5</sup>, Andreas Glindemann<sup>6</sup>, Jeter Hall<sup>7</sup>, Jamie Holder<sup>8</sup>, Richard Holmes<sup>9</sup>, Pierre  
Kervella<sup>10</sup>, David Kieda<sup>1</sup>, Etienne Le Coarer<sup>5</sup>, Stephan Lipson<sup>12</sup>, Fabien Malbet<sup>5</sup>, Sébastien Morel<sup>6</sup>,  
Paul Nuñez<sup>1</sup>, Aviv Ofir<sup>11</sup>, Erez Ribak<sup>12</sup>, Swapan Saha<sup>13</sup>, Markus Schoeller<sup>6</sup>, Boris Zhilyaev<sup>14</sup> and  
Hans Zinnecker<sup>15</sup>

<sup>1</sup> Department. of Physics, University of Utah, 115 S 1400 E, Salt Lake City, UT 84112-0830, USA

<sup>2</sup> Department of Astronomy, University of Padova, 35122 Padova, Italy

<sup>3</sup> School of Physics and Astronomy, University of Leeds, Leeds, LS2 9JT, UK

<sup>4</sup> Lund Observatory, Box 43, SE-22100 Lund, Sweden

<sup>5</sup> Laboratoire d'Astro. de Grenoble, 414 rue de la Piscine, 38400 Saint-Martin d'Hères, France

<sup>6</sup> ESO, Karl-Schwarzschild Str.-2, 85748, Garching-bei-Mnchen, Germany

<sup>7</sup> Fermilab, PO Box 500 Batavia, IL 60510, USA

<sup>8</sup> Department of Physics and Astronomy, University of Delaware, Newark, Delaware, USA

<sup>9</sup> Nutronics Inc., 3357 Chasen Drive, Cameron Park, CA 95682, USA

<sup>10</sup> LESIA, Observatoire de Paris-Meudon, 5, place Jules Janssen, 92195 Meudon, France

<sup>11</sup> Dept. of Astronomy and Astrophys., Tel-Aviv University, P.O. Box 39040, Tel-Aviv 69978, Israel

<sup>12</sup> Department of Physics, Technion - Israel Institute of Technology, Haifa 32000, Israel

<sup>13</sup> Indian Institute of Astrophysics II Block, Koramangala, Bangalore 560 034, India

<sup>14</sup> Main Astronomical Obs., NAS of Ukraine, 27 Akademika Zabolotnoho St., 03680 Kyiv, Ukraine

<sup>15</sup> Astrophysikalisches Institut Potsdam, An der Sternwarte 16, D-14482 Potsdam, Germany

## ABSTRACT

**Building on technological developments over the last 35 years, intensity interferometry now appears a feasible option by which to achieve diffraction-limited imaging over a square-kilometer synthetic aperture. Upcoming Atmospheric Cherenkov Telescope projects will consist of up to 100 telescopes, each with  $\sim 100\text{m}^2$  of light gathering area, and distributed over  $\sim 1\text{km}^2$ . These large facilities will offer thousands of baselines from 50m to more than 1km and an unprecedented (u,v) plane coverage. The revival of interest in Intensity Interferometry has recently led to the formation of a IAU working group. Here we report on various ongoing efforts towards implementing modern Stellar Intensity Interferometry.**

Keywords: Intensity Interferometry, Air Cherenkov Telescopes

## 1 INTRODUCTION

The development of optical Intensity Interferometry (I.I.) led by Robert Hanbury Brown and Richard Twiss in the 50's (Hanbury Brown 1974) was one of the inspirations for the foundation of quantum optics by Roy Glauber (Glauber 1963). The experiment conducted at Narrabri from 1963 to 1971 was the only implementation of a stellar intensity interferometer. Since then, all stellar interferometers have been based on Michelson's technique. In the recent years, however, I.I. has seen a revival of interest, due to the availability of modern signal processing technology and the development of Air Cherenkov Telescope (ACT) arrays of large aperture light collectors. Renewed enthusiasm for the abandoned technique has recently resulted in the formation of an IAU working group, to study the scientific motivation and technical approaches for implementing I.I. as a practical tool for astrophysical measurements. The authors of this contribution to the 2008 SPIE meeting in Marseille are the present members of this working group who should be contacted by anyone interested in joining this effort. In this paper, after briefly describing the principles and capabilities of I.I., we present a review of the known recent and ongoing efforts towards reviving I.I., including developments in telescopes, photo-detection, signal communication, signal processing and correlators and phase recovery analysis. Before concluding we outline some science topics that could particularly be addressed with I.I. implemented on a future large ACT array.

## 2 INTENSITY INTERFEROMETRY

### 2.1 Classical picture of Intensity Interferometry

Michelson interferometry relies on the visibility of interferometric fringes to provide a measurement of the mutual degree of coherence between different telescopes. The complex degree of coherence depends on the distance between the two receivers as the normalized Fourier transform of the source intensity distribution projected on a line parallel to the line joining the two detectors. The original image can then be reconstructed provided the phase can be recovered. An Intensity Interferometer does not rely on actual light interference, instead, the mutual degree of coherence is obtained from the measurement of the degree of correlation between the fluctuations of intensity recorded with a quadratic detector at different telescopes. The principal component of the intensity fluctuation is the classical shot noise which does not show any correlation between two separated telescopes. In addition to the shot noise, there is a smaller component, the wave noise, which can be described as the beating between the different Fourier components of the light reaching the telescopes. The wave noise shows correlation between the two detectors (see Figure 1) provided there is some degree of coherence between the light at the two detectors. Because of this correlation, the time integrated product of the intensity fluctuations is positive and provides a measurement of the square of the degree of coherence of the light at the two detectors (Labeysrie et al. 2006). The important point is that the correlation is a function of the difference in phase between the low frequency beats at the two detectors. This correlation does not depend on the phase difference of the light at the two detectors. The requirements for the mechanical and optical tolerances of an intensity interferometer are therefore much less stringent than in the case of a Michelson interferometer. This is important, as in principle it greatly facilitates the implementation of very large baselines without any extra complication associated with shorter wavelength or atmospheric turbulence. In particular, I.I. eliminates the need for adaptive optics and optical delay-lines. In addition, I.I. being insensitive to seeing conditions, it also relaxes the site requirements. On the other hand, with I.I., copious quantities of light, and therefore very large light collectors are necessary for the tiny wave beating to be measurable over the much more dominant shot noise. The tolerance of I.I. to path length differences makes such light collectors relatively inexpensive. An intensity interferometer with 1GHz signal bandwidth, does not need the optical surface of each collectors to be much more accurate than 3cm and the pointing does not needs to be controlled to better than a few arc-minutes for 10m telescopes. Furthermore, I.I. appears as the only existing tool for high resolution studies in the entire visible range, including the shorter wavelengths which provide a higher contrasts between regions at different temperatures and give access to bluer and hotter stars.

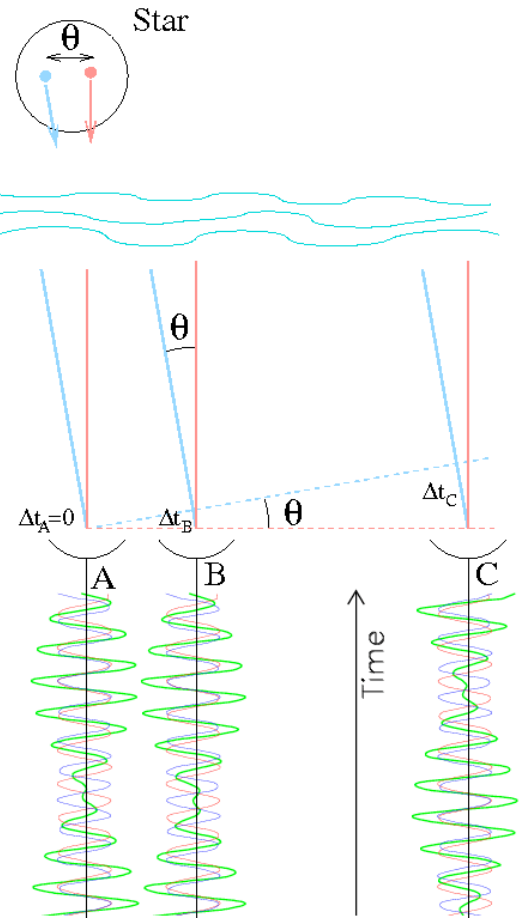

Figure 1: Two points of a star are emitting light with slightly different frequencies (blue and red) and produce beating at each telescope (green). The two waves shift in time with respect to one another according to the telescope position and affecting the relative phase of the beating at the different telescopes. Telescopes A and B being close together, the beatings they record are in phase and the correlation is high while for A and C the beatings are in phase quadrature and the correlation is small.

### 2.2 Capabilities of a Stellar Intensity Interferometer

The angular resolution  $\Delta\theta$  offered by any interferometer is related to the baseline  $d$  and wavelength  $\lambda$  as  $\Delta\theta \approx \lambda/d$ . A telescope array with baselines up to 1km as in planned ACT (CTA 2008, AGIS 2008) arrays would consequently give access to angular resolutions in the visible band better than a nanoradian or 0.2 milli-arc-second (mas). The next important aspect of the performance of an interferometer is the sensitivity. In a first approximation the signal to noise ratio in an Intensity Interferometer is given by (Hanbury Brown 1974):  $(S/N)_{RMS} = A \cdot \alpha \cdot n \cdot |y|^2 (\Delta f T / 2)^{1/2}$  where  $A$  is the

telescope collection area,  $\alpha$  is the photo-detector quantum efficiency,  $n$  the source spectral density,  $\gamma$  the complex degree of coherence,  $\Delta f$  the signal bandwidth of the signal processing and  $T$  the observation time. This relation accounts well for the achievements of the Narrabri interferometer which consisted of two telescopes 6.5m in diameter with  $\alpha=15\%$  and  $\Delta f=100\text{MHz}$  used for the measurement of the diameters of stars with visual magnitude as large as 2.5. With larger modern ACT,  $A=100\text{m}^2$  (section 3), high efficiency photo-detectors  $\alpha=60\%$  (section 4) and high bandwidth electronics  $\Delta f=1\text{GHz}$ , one pair of telescopes could in principle be used to measure  $|\gamma|^2=0.5$  at the 5 standard deviation level in 5 hours for a star of magnitude 7.4. This would provide a measurement of the star diameter with a statistical error of 14%. In the same amount of time the diameter of a visual magnitude 5.7 star would be measured with a statistical error of 3% (LeBohec & Holder 2006). This assumes only one baseline and one optical channel. Figure 2 demonstrates that with such instruments and baselines of up to 1km stellar disk resolution would be possible for main sequence stars up to 3pc distances, for giant branch stars up to more than 30pc and for super-giant branch stars up to more than 300pc. Other objects such as binary stars and emission lines from circumstellar material could also be studied (see section 8). Some astrophysical objects like young stellar objects, evolved stellar system, planetary nebulae and even stellar surfaces with the presence of a hot spot have the property to keep an unresolved component even at kilometer baselines which contribute significantly to the distribution of flux. In these conditions, the degree of coherence  $\gamma$  does not decrease to zero but remains at a significant level, helping the detection of features even at very long baselines provided a sufficient coherence resolution can be achieved.

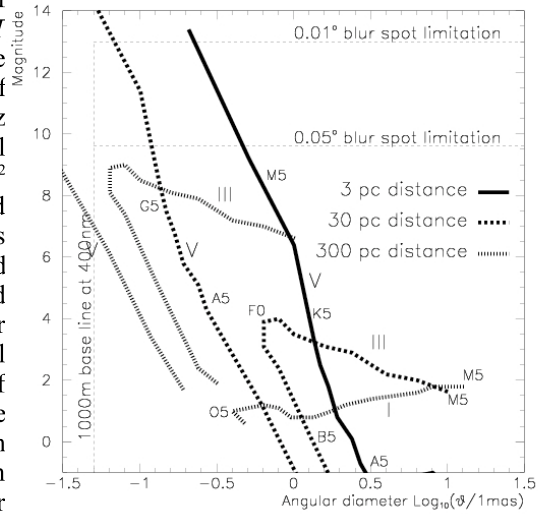

Figure 2: Visual magnitude-angular diameter relationship for main sequence and giant and super giant branches for distance 3pc, 30pc and 300pc compared to anticipated interferometry capabilities of planned ACT arrays.

### 3 TELESCOPES

#### 3.1 Air Cherenkov Telescope arrays for gamma-ray astronomy

The ACT technique relies on the fact that high energy particles, including gamma-rays, when entering the atmosphere, initiate extensive “air showers” of high energy secondary particles, some charged and radiating Cherenkov light. When it reaches the ground, the Cherenkov flash from a shower is very brief: only a few nanoseconds. It is also very faint,  $\sim 10$  photons/m<sup>2</sup> per 100GeV incoming gamma-ray and large light collectors equipped with fast electronics are necessary. In order to record stereoscopic views of each shower, ACTs are now generally used in arrays of 2 to 4 units with typically 100m inter-telescope distances (Figure 3), to match the extent of the Cherenkov light pool. The HAGAR (High Altitude GAMMA Ray) experiment is deploying 7 4.4m<sup>2</sup> telescopes in a centered hexagonal array offering 21 baselines from 50m to 100m (Chitnis et al 2005). Future projects such as CTA or AGIS aim at improving the gamma-ray flux sensitivity by increasing to several square kilometers the area covered by the array with several tens of telescopes. These arrays, when used as an interferometers, would allow to probe angular scales from a few mas to a few hundredths of a mas (Figure 4).

At Narrabri, the two telescopes could be moved along tracks to keep the signals in time and maintain a fixed baseline as the star was tracked for long periods of time. In ACT arrays, telescopes are at fixed locations. Signals from different telescopes must be aligned in time for the correlation to be measured. Analog or even digital programmable delays can be used for this. As in Michelson interferometers, because of the geometrical projection effect, the effective baseline between two telescopes changes during the observation of a star. This can be taken into account at analysis time. However, in ACT arrays, there are no close pairs of telescopes with which to obtain almost zero baseline measurements. Aside from installing extra telescopes in the array, it is possible to obtain a zero baseline measurement from single telescopes by splitting the beam of collimated and filtered light. The correlation of the fluctuations in the two beams from one telescope then provides a zero baseline measurement of the coherence.



Figure 3: The two telescopes used in the Narrabri interferometer (left) have many common points with present air Cherenkov telescopes such as in VERITAS (right). The VERITAS telescopes are 12m in diameter while the Narabri telescopes were 6m in diameter.

In an ACT, the pixel size is typically set to  $0.1^\circ$ -  $0.2^\circ$  and the optics is designed to produce a point spread function matching the pixel size. The finite size of the point-spread function makes it impossible to avoid also having some amount of night sky background (NSB) light polluting the star light. If 40% of the collected light is not coming from the star, the time necessary to attain a given significance for the measurement of the correlation is increased by a factor two. The NSB spectral density is close to  $5 \cdot 10^3 \text{m}^{-2} \text{s}^{-1} \text{Hz}^{-1} \text{sr}^{-1}$  and with a point spread function of  $0.05^\circ$  as in HESS and VERITAS, for example, stars of magnitude 9.6 are the dimmest that could practically be measured (LeBohec & Holder 2006). Better optics could in principle give access to fainter stars but, even with a large array like CTA, the necessary observation times quickly become impractical for stars with magnitude greater than 11.

With aperture ratios close to unity, in order to obtain good imaging capability over the widest fields of view possible, many ACT such as in HESS and VERITAS follow the Davies-Cotton design, which does not preserve isochrony (Davies & Cotton 1957). For 12m telescopes with aperture ratio close to one, this results in an effective signal bandwidth limitation close to 100MHz. With these telescopes, it is therefore not possible to improve sensitivity over the Narrabri intensity interferometer by utilizing the larger bandwidths nowadays available. The MAGIC and CANGAROO telescopes have parabolic mirrors which do not cause any time dispersion. For these telescopes, it would probably be possible to use much higher bandwidth, probably up to  $\sim 1\text{GHz}$  as we assumed in section 2.2 and possibly more, the limitation coming from the telescope pointing accuracy.

With their own advantages and limitations, it seems ACT arrays are almost ideal for I.I.. If interferometry capability is not implemented directly in the high energy camera, all the necessary collimation and filtering optics with associated photo-detectors could be mounted on a plate to be installed in front of the high energy camera (Deil et al. 2008) for interferometric observations. These large gamma-ray astronomy facilities already have scientific programs which are incompatible with interferometry observations. However, in practice, ACTs can only be used for gamma-ray science

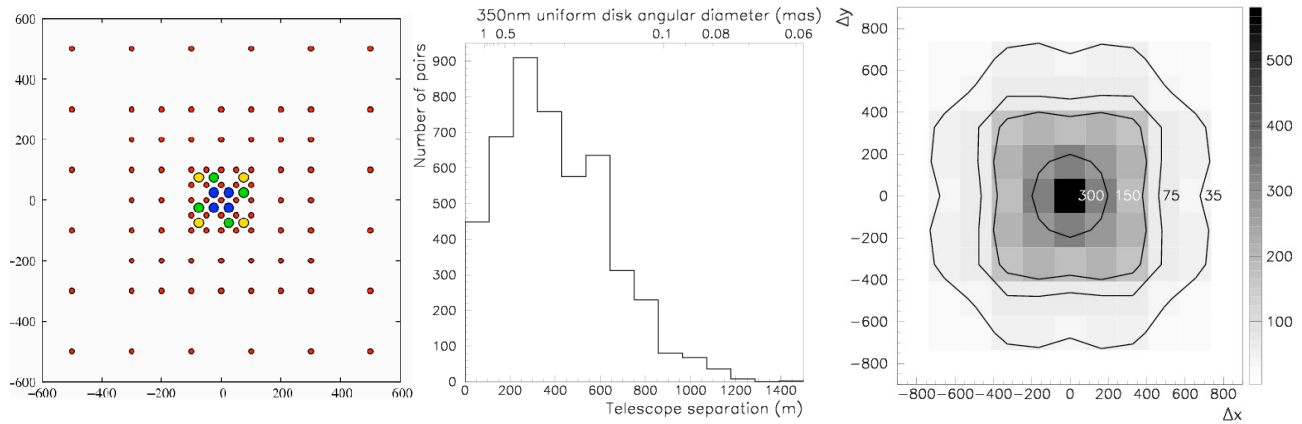

Figure 4: The CTA project might consist of 12  $600\text{m}^2$  telescopes surrounded by 85  $100\text{m}^2$  telescopes distributed over a square kilometer (left) offering a total of 4656 simultaneous interferometric baselines ranging from 35m to 1410m (center) resulting in a unique coverage of the  $(u,v)$  interferometric plane (right)

when the Moon is less than ~half full. Stray light from the Moon will only slightly reduce the sensitivity of an intensity interferometer and telescope time allocation could be set according to the Moon visibility, leaving almost half the night time available for interferometry measurements.

### **3.2 Extremely Large Telescopes**

Although the baselines offered by Extremely Large Telescopes (ELT) are rather smaller than the hundreds of meters discussed above, ELTs also offer possibilities for intensity interferometry, provided they are outfitted with a suitable high-speed photon-counting instrument. The entrance pupil can be optically sliced into a hundred segments, each feeding a separate detector. Different means of electronically combining the signal in software would yield either a photometric signal of very high time-resolution using the collecting area of the entire telescope or – by suitable cross correlations – intensity interferometry between various pairs of telescope sub-apertures (Dravins et al. 2005). Since intensity interferometry is largely immune to atmospheric turbulence, such observations would normally be made when seeing conditions are inadequate for adaptive-optics operations, and would be practical already with the main mirror being only partially or sparsely filled with mirror segments (a situation likely to last for several years during the ELT construction phase, given the huge number of mirror segments that will make up its primary). Furthermore, since intensity interferometry is not limited to operate at long wavelengths (other than by detector sensitivity and the atmospheric cutoff), the achievable spatial resolution will be superior by a factor of 2-3 to that feasible by adaptive optics, given its current limitation to operate in the red or near-infrared. It is also possible to consider even larger apertures that could be constructed drawing from the experience with large radio telescopes such as Effelsberg (2008) or Green-Bank (2008) with collection areas of 7850m<sup>2</sup>. Large light collectors like ELT or possible future larger projects could also be used for photo-correlation spectroscopy, the temporal equivalent to intensity interferometry which would in principle permit to achieve very high resolving power (Dravins & Germanà 2008) and relies on the same methods and technology as I.I..

## **4 PHOTODETECTION**

Since the time of the Narrabri interferometer, many advances in photo-detection have been made which could benefit the implementation of a modern Intensity Interferometer (Morel & Saha 2005). Important aspects to consider are the quantum efficiency, the electronic signal band-width and the excess noise. Photo-multipliers with GaAsP photo-cathodes have quantum efficiency curves peaking close to 50%. Solid state photo-detectors with quantum efficiencies reaching over 70% seem very attractive. Until recently, large area photo-diodes, required for practical use in I.I., did not offer competitive electronic noise and bandwidth when compared to photomultiplier tubes, which provide an electronic bandwidth of over 1GHz. This may be changing with arrays of Geiger-APDs on a single substrate which offer detection efficiencies close to 60%. These devices are now becoming available with high signal bandwidth and gains from 10<sup>5</sup> to 10<sup>6</sup>. The Geiger mode of operation also provides an excess noise much smaller than in standard photo-multipliers. On the negative side, they have the inconvenience of a temperature sensitive gain. They are also non-linear under high illuminations as the detector element dead time is responsible for a decrease in the number of active elements when the photon rate increases. These photo-detectors are, however, being considered for ACT high energy imaging cameras (Otte et al. 2007) and should be investigated for I.I. projects also.

## **5 HIGH BANDWIDTH COMMUNICATION**

Collecting high bandwidth signals from a number of receivers over kilometer distances is an important challenge for stellar I.I.. Signals from each receiver must be collected at a central station where the correlations are produced. Signals can be sent in their analog form to be digitized at the central station or they can be digitized locally and communicated in their digital form. The latter option has the advantage of minimizing the risks of contamination by any common source of noise that would cause artificial positive correlations. Signals could also be recorded locally and analyzed off-line. This option would still require high speed communication between the central station and each receiver as the digitization at each telescope should be well synchronized. Because of signal dispersion, coaxial cables can not be used over the large distances across an ACT array for the high bandwidths required by I.I.. Optical links, on the other hand, can transmit nanosecond rise times over hundreds of meters. They also experience no cross-talk, no electromagnetic pickup and solve all grounding problems.

Typically employed in digital systems, Vertical Cavity Surface Emitting Lasers (VCSELS) are readily available low power, low cost laser diodes which can also be used in analogue transmission as demonstrated with prototypes developed in Leeds by the group led by J.Rose (Rose et al. 2000). These tests have demonstrated their ~500MHz bandwidth capability, better than 10% linearity over a 60dB dynamic range over 100m distances. The MAGIC collaborations has been successfully using such devices for analog signal transmission in their high energy gamma-ray observations for a few years already (Bartko et al. 2005).

The same group at the University of Leeds has also developed a Digital Asynchronous Transceiver (DAT, White et al.



2007) system used at the VERITAS observatory to transmit trigger signals, event numbers and house keeping information between the telescopes of the array and the central array control building. The same or modified units could be used in an Intensity Interferometer to distribute clock signals for synchronizing digitization, collect data and transmit slow control commands. The Leeds DAT have a capability of 1.25Gbit/s over a range of 800m.

## 6 CORRELATORS

In an intensity interferometer, the DC component of the signal at each telescope must be measured and recorded while the AC components must be sent to the input of the correlator operating in real time or recorded for off-line analysis. In Narrabri, the correlator consisted of a 4-transistor based linear multiplier, the output of which was integrated over 100s time windows. Double phase switching was used in order to avoid the signal drifting away from the zero point, which would otherwise drown the correlation signal. The signals from the two channels were inverted at 10kHz and 10Hz frequencies respectively. The switching frequencies were then amplified and demodulated before the signals were integrated. This clearly was the critical part of the experiment and great efforts had to be made in order to reduce spurious correlations to acceptable levels. Nowadays, an intensity interferometer would take advantage of available fast digital electronics. Two approaches can be taken.

In one approach the photo-detector output signal is digitized by a Flash Analog to Digital Converter providing a stream of measurements of the signal amplitude in each telescope which have to be correlated. This approach is being pursued by the group of S.LeBohec at the University of Utah. In their correlator prototype, two input signals are digitized into 12bits at a 200MHz rate. A Field Programmable Gate Array (FPGA) collects the samples from both Flash Analog to Digital Converters (FADC). After a 5ns resolution programmable delay (also implemented in the FPGA), the samples are multiplied and accumulated in a register. In order to obtain finer control of the relative timing of the signals, the FPGA programs 0.6ns steps analogue delays on each input. The FPGA also controls the analogue phase modulation. The demodulation is obtained by alternately adding and subtracting the sample's product, according to the states of the analogue phase switches (see Figure 5 and LeBohec et al. 2008). This allows for the effects of slow analogue drifting, offsets and FADC pedestals to be canceled out. The FPGA is also programmed to include a processor that handles serial communication and data-transfer with a computer. This prototype is now fully working and tests in the laboratory with an artificial source and two photo-multipliers are under way.

Another approach consists in working directly with the photon streams. The photo-detector is then working in photon counting mode as is the case with an avalanche photo-diode operated in Geiger regime or with a conventional photomultiplier tube with a discriminator on its output with the threshold set at the single photon level. This approach requires a relatively low photon count for single photon pile up to be avoided. This can be obtained even for luminous objects and large light collectors by increasing the number of optical channels. This approach is pursued by D.Dravins at the Lund Observatory with the design of the QantEYE instrument primarily in view of applications with ELT as outlined in section 3.2. This also inspired a recent series of test by the same group together with the VERITAS collaboration. These tests used pairs of the 12-meter diameter telescopes of the VERITAS array on Mt.Hopkins in Arizona. The baselines between different pairs of its four telescopes range between 34 and 109 meters. Starlight was detected by a photon-counting photomultiplier in the central pixel of the regular Cherenkov-light camera, the outgoing photon pulses were digitized using a discriminator, pulse-shaped to a width down to some 5ns, and then transmitted from each telescope via an optical cable to the control building where they entered a real-time digital correlator (manufactured by *Correlator.com*), computing the cross correlation function for various time delays, with a time resolution of 1.6 nanoseconds. Continuous count rates up to some 30 MHz were handled, limited by the digitization and signal-shaping electronics. Actually, to limit the count rates, the detectors on each telescope were masked down to admit only some percent of the incoming starlight so that, in a future optimized setup, the stellar signal can be of very much higher fidelity than achieved here. Even if the present data were not processed for full time-delay normalization, and may be affected by unidentified noise sources, we believe these experiments represent the first case of optical astronomical telescopes having been connected for real-time observations through *e*-interferometry by digital software rather than by optical links

The types of low budget correlators described above could already be beneficially replaced by correlators developed for

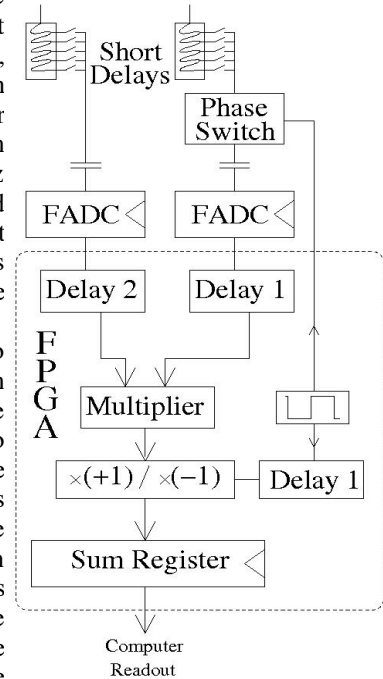

Figure 5: Functional schematic of the correlator under development at the University of Utah, see text for details.

the ALMA project (ALMA 2008). The ALMA correlator is being designed to combine the 8GHz bandwidth outputs of up to 64 array millimeter wavelength antenna elements with separations up to 18.5km (Escoffier et al. 2007). A third approaches offers the greatest flexibility in the range of analysis it makes possible. As mentioned earlier, the signal at each receiver could be recorded in full to be used in off line correlation analysis. Each data stream must include timestamps for accurate synchronization. The main challenge is the huge amount of data that must be collected: more than 1Gb every second for each receiver with GHz signal bandwidth. This is however becoming possible and should be considered for any important future project.

## 7 INTENSITY INTERFEROMETER DATA ANALYSIS

Since the time of the Narrabri interferometer, it was demonstrated, theoretically first (Gamo 1963) and then experimentally (Sato et al. 1978, Fontana 1983) that even with I.I., phase information can be recovered with a system consisting of three or more telescopes, by analyzing third and higher order correlation functions. This is actually also clearly demonstrated in these proceedings by Boris Zhilyaev (2008) using the Fourier properties of bispectra. With I.I., as with Michelson interferometry, model-independent reconstruction of the object image is possible. This was since then explored and confirmed by several authors (Marathay et al. 1994, Vildanov et al. 1998). Correlation of order larger than two are however difficult to achieve as they are noise sensitive in a way that increases with the order.

Conversely, it was recently shown that if, indeed, higher order correlations could be measured, then the sensitivity of the instrument can be improved (Ofir & Ribak 2006A and 2006B). In their analysis, Ofir and Ribak at the Technion assume a full recording and off-line processing of all of the data. This allows for the entire correlation function to be measured, possibly in multiple optical bands simultaneously. They show that averaging individual reflectors over relatively long periods (seconds) will provide extremely high quality photometry of each target. Furthermore the high redundancy offered by a large telescope array with off-line signal processing capability allows to compute not just the second order intensity correlation between any two detectors, but also the  $m^{\text{th}}$  order correlation of any  $m$ -sized subgroup of detectors. This can be used to effectively increase the overall signal to noise ratio (SNR) via the usual square-root scaling. For illustration, Figure 6 shows the SNR of several linear arrays as a function of the number of elements  $N$  – each with a collecting area  $A$  as indicated on the left. The overall behavior of all the lower plots with respect to  $N$  is tapering down with increasing  $N$  – the translational symmetry behavior. Apart from this, the change in behavior of the 7680m<sup>2</sup> plot implies that a new element becomes important around  $N \approx 10 - 20$ . This new element is the transition from the redundancy dominated by pairs of elements, to redundancy dominated by triplets. Later, quadruplets start to contribute even more than the triplets at  $N = 29$ , and then - successively - quintuplets, sextuplets, septuplets, octuplets and nonuplets (at  $N = 99$ ). The end result is a long exponential rise resulting from the stacking of all the above contributions. Similarly, a more subtle transition to triplets domination can be observed also for the  $A = 1920\text{m}^2$  array around  $N = 54$ , and such transitions are expected for the lower telescope area plots at  $N > 100$ .

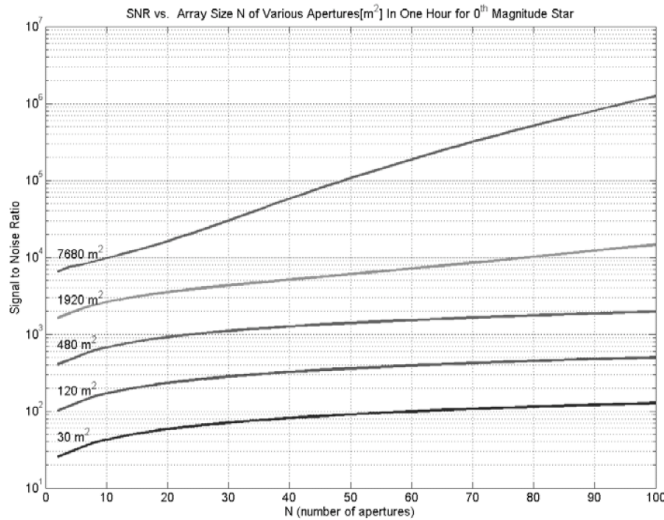

Figure 6: Signal to noise ratio as a function of the number of apertures for a 0<sup>th</sup> magnitude star observed during 1 hour taking advantage of high order correlations, see text for details.

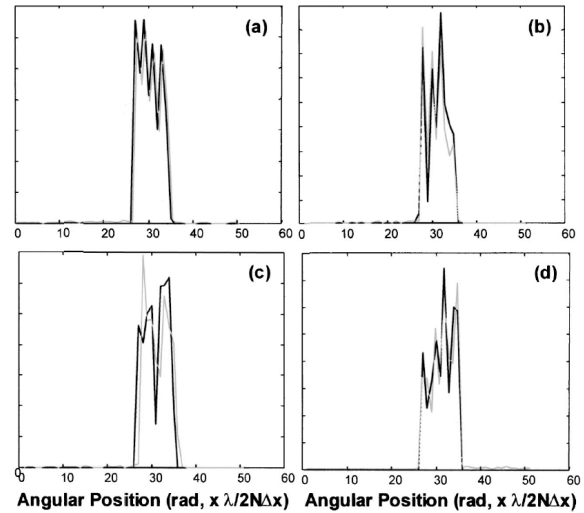

Figure 7: Random one dimensional profiles (black) and their reconstruction (grey) from simulated intensity interferometry observation, see text for details.

Getting back to the phase recovery problem, Richard Holmes (Holmes & Belen'kii 2004) from Nutronics recently demonstrated that the magnitude of the Fourier transform of the image as provided by an intensity interferometer can be described by an analytical function to which the Cauchy Riemann equations apply to retrieve the phase with a generally minimal ambiguity. The actual image can be recovered independently from any specific model of the observed object. The capabilities of this method are illustrated on Figure 7 for a collection of random one dimensional objects with 60 sampling points in the Fourier space corresponding to a linear receiver array of less than 12 receivers. A paper presenting a generalization of this algorithm to two dimensional arrays and images is in preparation (Holmes 2008).

## 8 ASTROPHYSICAL THEMES

Although impressive advances have been made in Michelson interferometry, baselines much longer than some hundred meters encounter serious issues in both atmospheric turbulence and in atmospheric physics that make ground-based observations very challenging or simply not practical. As a possible remedy, space-based telescope clusters flying as phase interferometers have been proposed to attain baselines up to kilometers such as with Stellar Imager (Klein et al. 2007, Carpenter et al. 2007) and Luciola (Labeyrie et al. 2007), which would be capable of imaging stellar surface details even in the ultraviolet. However, the considerable complexity and probable expense of these large-scale space missions makes the timescale for their realization somewhat uncertain, prompting searches for alternative approaches such as I.I. In the previous sections, we have seen that an Intensity Interferometer with kilometer baselines and imaging capabilities for stars with visual magnitude as great as 8 or more could be deployed in the coming 5 years. Here, we are briefly highlighting a few potential science topics that could be addressed with a large scale interferometer:

- Pre-main sequence (PMS) evolution could be studied by measuring stellar angular size to calibrate evolutionary tracks or by observing hot and cold spots associated with mass accretion and magnetic activity (de Wit et al. 2008). There are ~50 known PMS stars with  $m_v < 8$  within 50pc that could be studied with ACT arrays with I.I. capabilities. Also, the  $H\alpha$  line is usually very strong in young stars and related to the energetic phenomena in their very close environment. I.I., by providing very high angular resolution in the visible domain, could become a key technique to unravel the intricacies of accretion and ejection of material during star formation.
- Atmospheric structures of super-giant stars can be studied including large-scale stellar convection. Predictions from three-dimensional dwarf star atmospheric models can also be tested from limb-darkening curves observed at different wavelengths (Dravins & LeBohec, 2008).
- Direct measurements of Cepheid angular sizes combined with photometric and spectroscopic measurement of the physical radius of the star gives access to the distance to the Cepheid (Sasselov & Marovska 1994). This allows the calibration of the all important Cepheid period-luminosity relation using local Cepheids. There are at least 60 Hipparcos Cepheids with  $m_v < 8$  (Groenewegen 1999) within reach of future I.I. capable ACT arrays. Longer period pulsating variable such as Mira stars show very large amplitudes with strong wavelength dependent distortions that could also be studied with these instruments (Dravins & LeBohec 2008).
- Rapidly rotating main-sequence dwarf stars naturally take on an oblate shape, with an equatorial bulge that for stars rotating close to their break-up speed may extend into a circum-stellar disk, while the higher effective-gravity regions near the stellar poles become overheated, driving a stellar wind. Photometric observations of Be star disks seem to indicate that they evolve and disappear. There are about 300 Be stars brighter than  $m_v = 8$ , roughly corresponding to a distance limit of 700pc, signifying that Be star phenomena can be probed in depth with ACT based I.I. (de Wit et al. 2008).

These are a few examples of stellar physics topics that would be strongly influenced by the availability of observations in the visible range through a kilometer scale I.I. based synthetic aperture. Other topics such as cataclysmic variable, close binaries with tidal interaction and mutual irradiation effects and others could certainly be addressed. Such an instrument, with the unprecedented resolution power in the visible band it will offer, would also certainly have a high exploratory potential.

## 9 CONCLUSIONS

The last five years have seen a revival of interest in stellar I.I., and more generally in exploiting the quantum properties of light in astronomical observations. I.I. appears as an interesting alternative to Michelson interferometry when considering the difficulties associated with kilometer-scale baselines and the effects of atmospheric turbulence for observations at the shortest wavelengths. Since the time of the Narrabri Interferometer, more than 35 years ago,



technological developments in the domains of photo-detection, high bandwidth signal synchronization, communication and processing as well as large data flow recording are making I.I. based on a large number of receivers realistic and even practical. The recent successes of ground based gamma-ray astronomy with the air Cherenkov technique make it likely that in the coming ten years we will see the deployment of kilometer arrays with up to one hundred 100m<sup>2</sup> light collectors. These arrays, if used for intensity interferometry, would give access to angular resolutions of a few tenths of nano-radians (hundred micro-arcseconds) for stars with visual magnitudes up to 9 or more. All of these aspects combined motivate the present interest in I.I. which has resulted in the formation of an Intensity Interferometry working group with the IAU. Several of the authors (Dravins, Hall, LeBohec, Ribak, ...) are conducting laboratory experiments to test and demonstrate various approaches to a modern implementation of I.I. A pair of 3m telescopes is now available in Utah (Star Base Utah 2008) for testing these techniques in a realistic astronomical environment without interfering with existing ACT observatories. These tests should soon demonstrate the capabilities of a modern Stellar Intensity Interferometry and converge toward specific strategies on which to base larger scale proposals to expand the scientific output of ACT arrays with the addition of I.I. capability. Ideally this stage should be reached in time for the design of ACT arrays to still be able to integrate I.I. specific requirements. Over longer time scales, the implementation of I.I. on ACT arrays could serve as a testbed for the design of possible space based version of intensity interferometry (Klein et al. 2007).

In summary, revisiting Intensity interferometry appears worthwhile and may provide a promising technique for high resolution stellar imaging.

### ACKNOWLEDGEMENTS

S.LeBohec acknowledges support from the University of Utah. C.Foellmi acknowledges support from the Swiss National Science Foundation (grant PA002—115328).

### REFERENCES

- ALMA, 2008, <http://www.alma.nrao.edu/>  
 AGIS, 2008, <http://cherenkovphysics.iastate.edu/wp>  
 Bartko, H. et al., 2005, NIMPA, 548,3, 464  
 Carpenter, K.G. et al., 2007 in UV/Optical Deep Space Telescopes: Innovative Technologies and Concepts III, ed. H.A. MacEwen and J.B. Breckinridge, Proc. SPIE 6687, 66870D, 12pp.  
 Chitnis, V.R. et al., 2005, in Proc. 29<sup>th</sup> ICRC, 00, 101, Pune, India  
 CTA, 2008, <http://www.mpi-hd.mpg.de/hfm/CTA/>  
 Davies, J. and Cotton, E., 1957, J. Solar Energy, 1, 16  
 de Wit W.J., et al., 2008, in The Universe at Sub-second timescales, Ed. D.Phelan, O.Ryan and A.Shearer, AIP Conf. Proc. 984, 268  
 Deil, C. et al., 2008, in The Universe at Sub-second timescales, Ed. D.Phelan, O.Ryan and A.Shearer, AIP Conf. Proc. 984, 140  
 Dravins D., Barbieri C., Da Deppo V., Faria D., Fornasier S., Fosbury R.A.E., Lindegren L., Naletto G., Nilsson R., Occhipinti T., Tamburini F., Uthas H., Zampieri L. 2005, QuantEYE. Quantum Optics Instrumentation for Astronomy, OWL Instrument Concept Study, ESO document OWL-CSR-ESO-00000-0162  
 Dravins, D. and Germanà, C., 2008, in The Universe at Sub-second timescales, Ed. D.Phelan, O.Ryan and A.Shearer, AIP Conf. Proc. 984, 216  
 Dravins, D. and LeBohec, S., 2008, in Extremely Large Telescopes: Which Wavelengths?, ed. T.Andersen, SPIE proc. Vol. 6986, DOI:10.1117/12.801260  
 Effelsberg, 2008, <http://www.mpifr-bonn.mpg.de/div/effelsberg/>  
 Escoffier, R.P., et al., 2007, A&A, 462, 801  
 Fontana, P.R., 1983, J. Appl.Phys., 54(2), 473  
 Gamo, H., 1963, J. Appl. Phys., 34, 4, 875  
 Glauber, R.J., 1963, Phys.Rev., 130, 6, 2529  
 Green-Bank, 2008, <http://www.gb.nrao.edu/>  
 Groenewegen, M.A.T., 1999, A&AS 139, 245  
 Holmes, R.B. and Belenkii, M.S., 2004, J. Opt. Soc. Am. A 21, pp. 697-706  
 Holmes, R.B., 2008, in preparation  
 Hanbury Brown, R., 1974, The intensity interferometer, Taylor & Francis LTD, London  
 Klein, I., Guelman, M. and Lipson, S.G., 2007, Appl. Opt., 46, 20, 4237  
 Labeyrie, A. et al., 2007, Luciola Hyperlescope Space Observatory, proposal to ESA Cosmic Vision plan 2015-2025  
 Labeyrie, A., Lipson, S.G., Nisenson, P., 2006, An Introduction to Optical Stellar Interferometry, Cambridge Univ. Press,

Cambridge

- LeBohec, S., et al., 2008, in *The Universe at Sub-second timescales*, Ed. D.Phelan, O.Ryan and A.Shearer, AIP Conf. Proc. 984, 205
- LeBohec S. and Holder, J., 2006, *ApJ* 649, 399
- Marathay, A.S., Hu, Y.Z. and Shao, L., 1994, *Opt. Eng.*, 33, 10, 3265
- Morel, S. and Saha, S.K., 2005, *21st Century Astrophysics*, Eds. S. K. Saha & V. K. Rastogi, Anita Publications, New Delhi, 237-257.
- Otte, A.N. et al., 2007, in Proc., 30<sup>th</sup> ICRC, OG.2.4, Merida, Mexico
- Ofir, A., and Ribak, E.N., 2006A, *MNRAS*.368.1646
- Ofir, A., and Ribak, E.N., 2006B, *MNRAS*.368.1652
- Paneque, D. et al., 2003, in Proc., 28<sup>th</sup> ICRC, 2927
- Rose, J. et al., 2000, *NIM A*, 442, 113
- Sasselov, D. and Karovska, 1994, *ApJ* 432, 367
- Sato, T., Wadaka, S. and Ishii, J., 1978, *Appl. Opt.*, 17, 13
- Star Base Utah, 2008, <http://www.physics.utah.edu/~lebohec/StarBaseWeb>
- Vildanov, R.R., et al., 1998, *Tr. J. of Phys.*, 22, 949
- White, R. J. et al., 2007, *NIMPA*, 577, 708
- Zhilyaev, B., 2008, "Bispectral technique for the reconstruction of the astronomical images with an intensity interferometer", these proceedings.
- Zuckerman, B. and Song, I., 2004, *ARA&A* 42, 685